

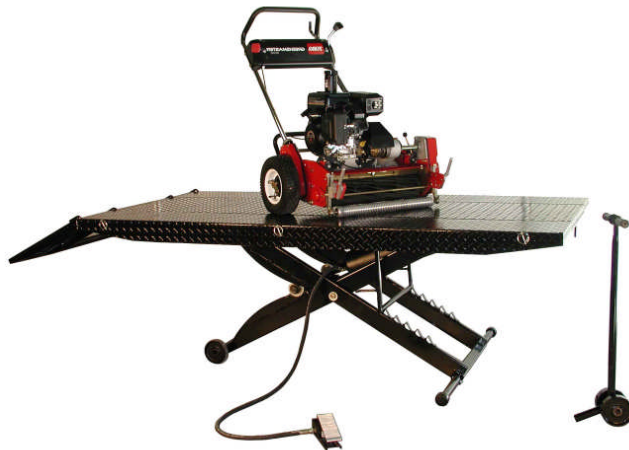

## **INSTRUCTION**

MODEL: GL-1

**1,000-Lbs. Capacity Equipment Lift**



## **GOLF-LIFT**

2950 S.E. LOOP 820 FORT  
WORTH, TX 76140  
TOLL FREE: 800-788-9789  
[WWW.GOLF-LIFT.COM](http://WWW.GOLF-LIFT.COM)

**WARNING: READ THIS INSTRUCTION  
BOOK COMPLETELY BEFORE OPERATING  
THE LIFT**

THIS IS A 1,000-LBS. CAPACITY EQUIPMENT LIFT. FAILURE TO FOLLOW ALL SAFETY AND SERVICE PRECAUTIONS MAY RESULT IN SERIOUS PERSONAL INJURY AND/OR PROPERTY DAMAGE.

<b>BASIC SPECIFICATIONS</b>
-----------------------------

	<b><u>GL-1</u></b>
Length	93"
Width	48"
Full Raise	33"
Fully Lowered	7-1/4"
Weight Capacity	1,000 lbs

**Inspection upon receipt of the lift**

1. Always inspect the lift for freight damage and make note of any damage on the bill of lading.
2. In case of freight damage, call the truck line immediately and report the damage as a freight claim.

**Final Set-Up for model GL-1**

This lift is more than 90% factory pre-assembled. The following steps will guide you through the final set-up.

1. Unpack the lift from the shipping skid. With the lift table up side down, connect the air hose to the air cylinder (Part # 26).
2. After tightening the hose to the cylinder, flip the lift over with the table surface up.

3. Connect the other end of the air hose to the foot-operated valve. Then connect the foot-operated valve to 100 PSI air supply. **DO NOT USE AIR SUPPLY WITH PRESSURE MORE THAN 100 PSI.**

4. Release the safety bar by pushing the handle down. Operate the foot valve by stepping on the foot pad forward to raise the lift. The safety bar should engage the ladder automatically while lift is rising. Step on the footpad again to set the pad in middle position to stop the lift when it reaches the desired height. **ALWAYS LOWER LIFT IN THE NEAREST LOCKED POSITION BEFORE BEGINNING WORK. NEVER USE THE LIFT UNLESS YOU ARE IN A LOCKED POSITION.** The lift should never be left unattended while attached to air pressure. Disconnect the air pressure when lift is not attended by qualified persons.

5. Install the approach ramp by dropping it into the holes punched on the rear edge of the table.

The final Set-Up for the GL-1 model is complete

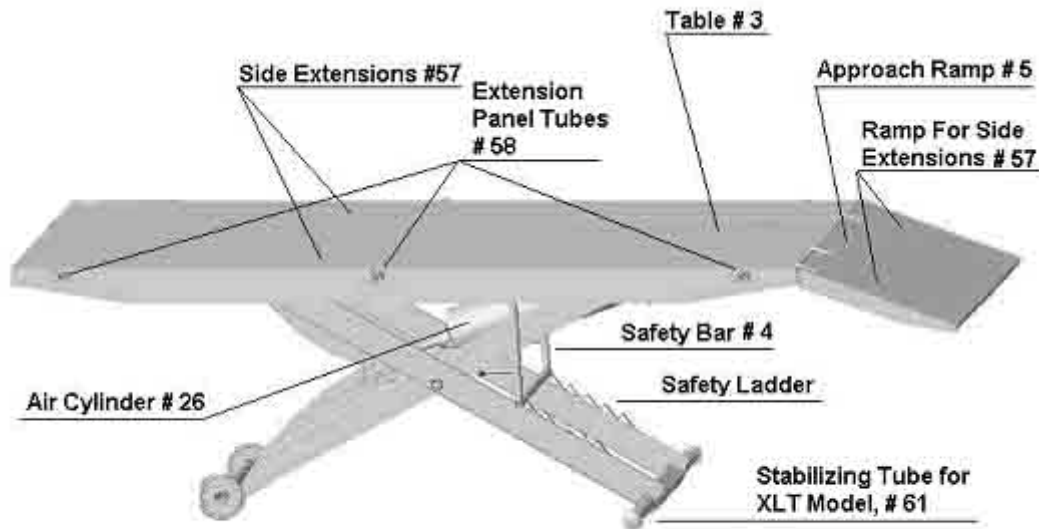

PLEASE REFER TO FIG #1 FOR ALL PART AND COMPONENT NUMBER

## **Final Set-Up for model GL-1**

After you finished the steps for the GL-1

7. Run the Extension panel tubes (Total Three, Part # 58) through the holes on the side of the table. Install the side extensions onto the protruding tubes. Using the clips supplied (part # 59) to secure the tubes.

8. Drop the ramps for the side extensions in place as shown above.

9. Run the Stabilizing tube through the square tube in the bottom of the lift. Secure it with screws supplied (parts # 64)

**The final Set-Up for the GL-1 model is complete**

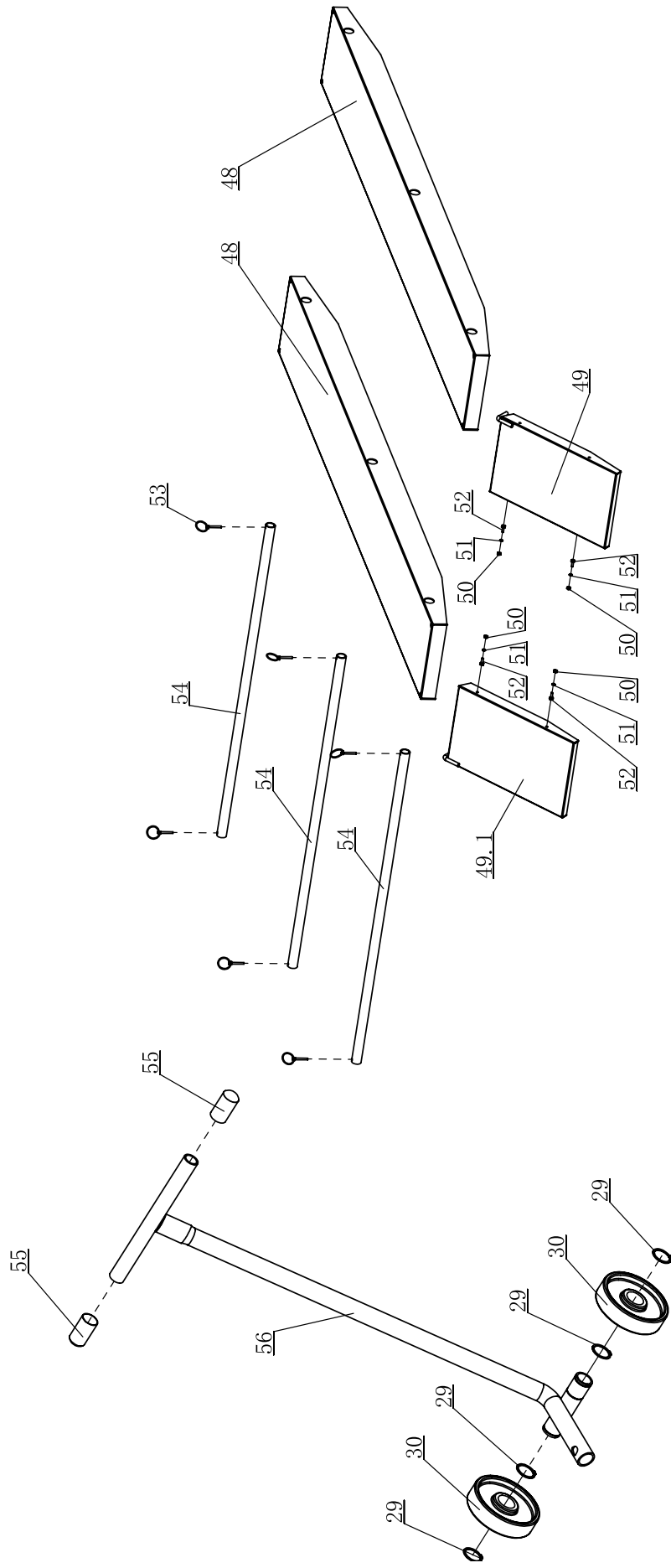

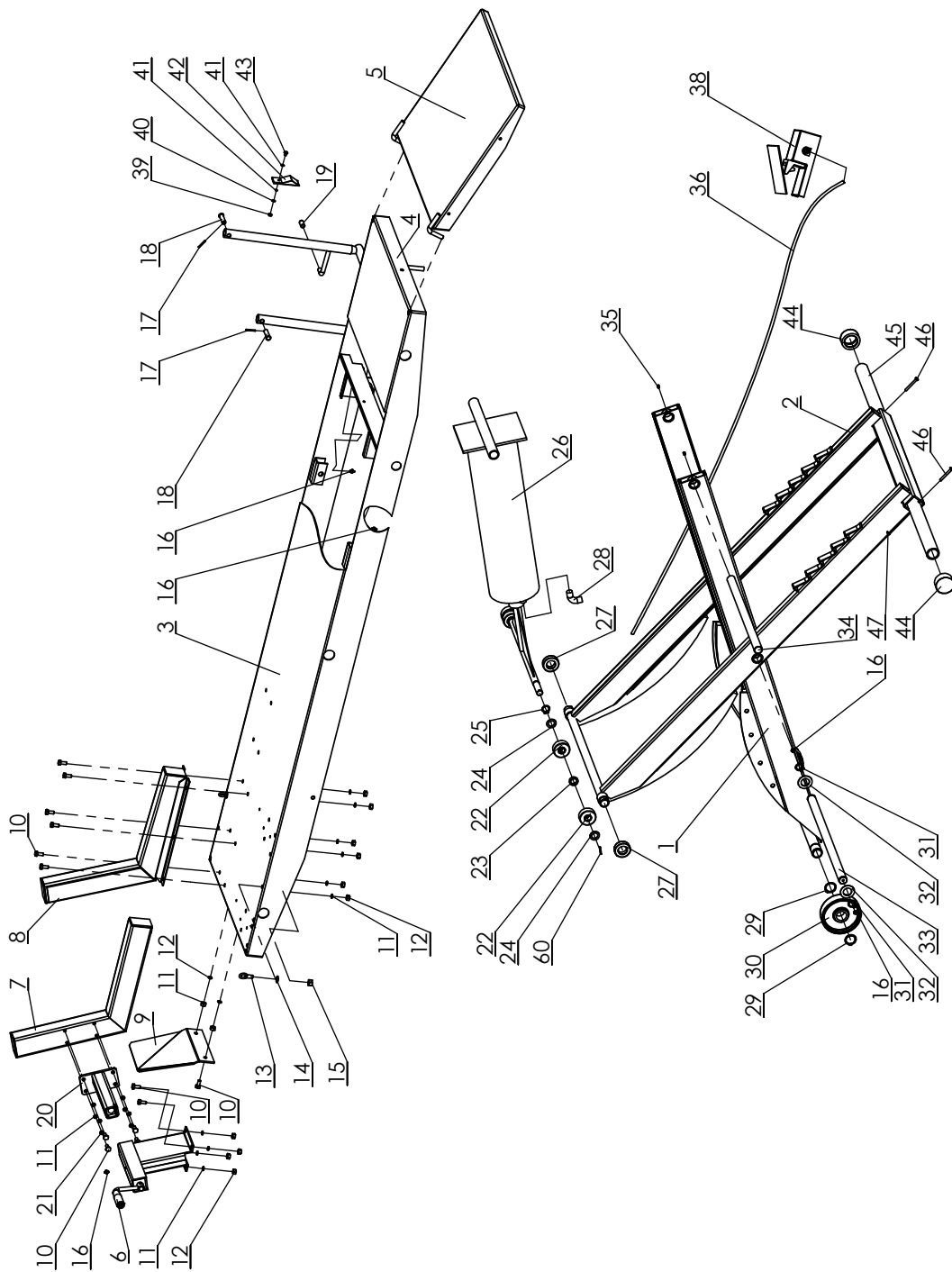

Item	Part Number	Description	Qty
1	AL-1000G	Scissor A-Outside	1
2	AL-2000G	Scissor B-Inside	1
3	AL-3000	Lift Table-Motorcycle lift (only)	1
4	AL-4000	Lock Bar	1
5	AL-5202	Center,Approach Ramp B	1
6	AL-5400	Vise Clamp Handle-Assy	1
7	AL-5302	Vise,Moving Jaw-Assy	1
8	AL-5301	Vise,Stationary Jaw	1
9	AL-5604	Wheel Stop	1
10	B10-8×20	Bolt M8×20	16
11	B40-8	Lock Washer Ø8	16

12	B30-8	Nut M8	12
13	B27-10×20	'Tie Down" Eye Bolt M10×20	2
14	B41-10	Flat Washer Ø10	2
15	B30-10	Nut M10	2
16	B85-6	Grease Zerk M6	5
17	B52-3×30	Cotter Pin Ø3×30	2
18	B53-12×45	Pin(B) Ø12×45	2
19	AL-4004	Plastic Grip/Safety Release	2
20	AL-5303	Moveable Vise Extension	1
21	B41-10	Flat Washer Ø10	4
22	AL-6006	Bearing/Cylinder	4
23	AL-6010	Spacer	2
24	B41-18	Flat Washer Ø18	4
25	B60-19	C-clip Ø19	2
26	YG09-9100	Air Cylinder	1
27	AL-6007	Bearing/Scissor	2
28	YG09-9106	Fitting	1
29	B60-32	C-Clip Ø32	4
30	AL-5501	Wheel	2
31	B60-25	C-Clip Ø25	2
32	AL-6005	Washer	2
33	AL-6003	Shaft/Scissor pivot	1
34	AL-6002	Shaft/Scissor pivot	1
35	B21-6×8	Set Screw M6×8	2
36	YG09-9301	Air Hose	1
38	YG09-9300	Foot-Operated Valve	1
39	B30-5	Nut M5	1
40	B40-5	Lock Washer Ø5	1
41	B41-5	Flat Washer Ø5	2
42	AL-6001	Lock Bar Holder	1
43	B10-5×16	Bolt M5×16	1
44	AL-5603	End Cap,Stabilizing Tube	2
45	AL-5602	Stabilizing Tube	1
46	B10-6×50	Bolt M6×50	2
47	B30-6	Nut M6	2
48	AL-5101	Side Extension	2
49	AL-5201	XLT Approach Ramp,Left Side EXT	1
49.1	AL-5201DC	XLT Approach Ramp,Left Side EXT	1
50	B30-6	Nut M6	6
51	B40-6	Lock Washer Ø6	4
52	B10-6×16	Bolt M6×16	4
53	AL-5605	Lock Clip Pins	6
54	AL-5601	Extension Panel Tube	3
55	B81-26	Plastic Handle Grip Ø26.8/Dolly	2
56	AL-5510	Dolly	1
60	B51-3x25	Pin Ø3x25	2