

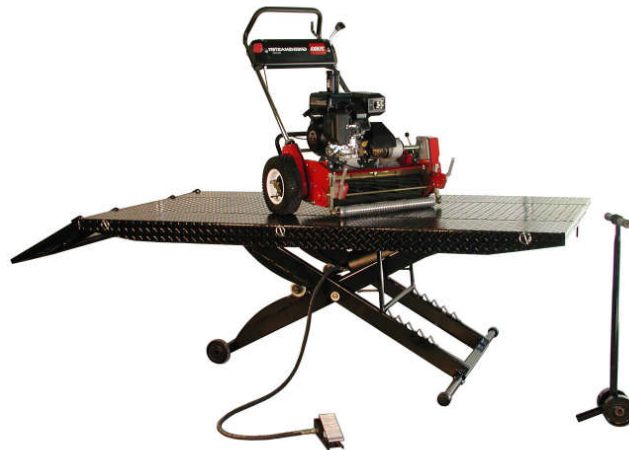

INSTRUCTION

MODEL: GL-1

1,000-Lbs. Capacity Equipment Lift



GOLF-LIFT

2944 S.E. LOOP 820
FORT WORTH, TX 76140
TOLL FREE: 800-788-9789
WWW.GOLF-LIFT.COM

**WARNING: READ THIS INSTRUCTION
BOOK COMPLETELY BEFORE OPERATING
THE LIFT**

THIS IS A 1,000-LBS. CAPACITY EQUIPMENT LIFT. FAILURE TO FOLLOW ALL SAFETY AND SERVICE PRECAUTIONS MAY RESULT IN SERIOUS PERSONAL INJURY AND/OR PROPERTY DAMAGE.

BASIC SPECIFICATIONS

	<u>GL-1</u>
Length	93"
Width	48"
Full Raise	33"
Fully Lowered	7-1/4"
Weight Capacity	1,000 lbs

Inspection upon receipt of the lift

1. Always inspect the lift for freight damage and make note of any damage on the bill of lading.
2. In case of freight damage, call the truck line immediately and report the damage as a freight claim.

Final Set-Up for model GL-1

This lift is more than 90% factory pre-assembled. The following steps will guide you through the final set-up.

1. Unpack the lift from the shipping skid. With the lift table up side down, connect the air hose to the air cylinder (Part # 26).
2. After tightening the hose to the cylinder, flip the lift over with the table surface up.

3. Connect the other end of the air hose to the foot-operated valve. Then connect the foot-operated valve to 100 PSI air supply. **DO NOT USE AIR SUPPLY WITH PRESSURE MORE THAN 100 PSI.**

4. Release the safety bar by pushing the handle down. Operate the foot valve by stepping on the foot pad forward to raise the lift. The safety bar should engage the ladder automatically while lift is rising. Step on the footpad again to set the pad in middle position to stop the lift when it reaches the desired height. **ALWAYS LOWER LIFT IN THE NEAREST LOCKED POSITION BEFORE BEGINNING WORK. NEVER USE THE LIFT UNLESS YOU ARE IN A LOCKED POSITION.** The lift should never be left unattended while attached to air pressure. Disconnect the air pressure when lift is not attended by qualified persons.

5. Install the approach ramp by dropping it into the holes punched on the rear edge of the table.

The final Set-Up for the GL-1 model is complete

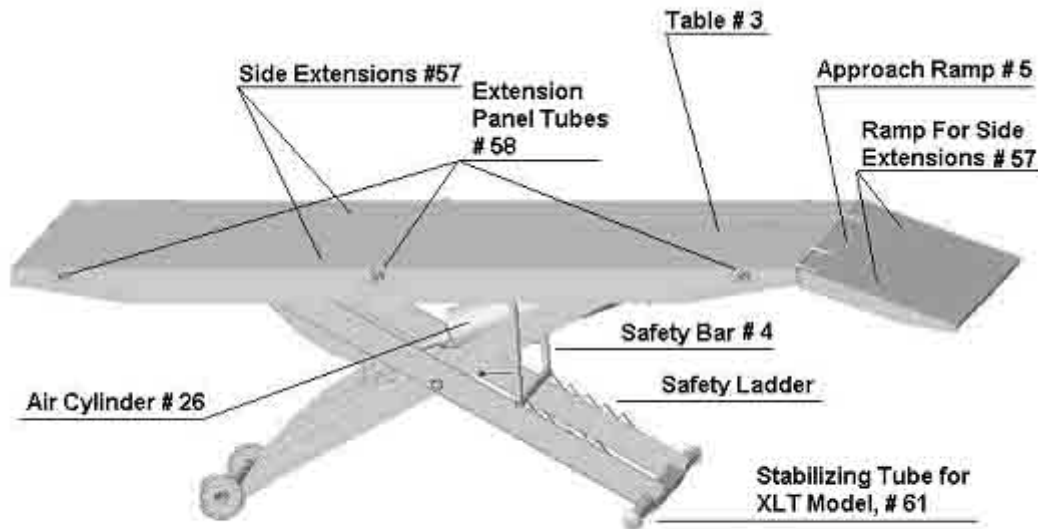

PLEASE REFER TO FIG #1 FOR ALL PART AND COMPONENT NUMBER

Final Set-Up for model GL-1

After you finished the steps for the GL-1

7. Run the Extension panel tubes (Total Three, Part # 58) through the holes on the side of the table. Install the side extensions onto the protruding tubes. Using the clips supplied (part # 59) to secure the tubes.

8. Drop the ramps for the side extensions in place as shown above.

9. Run the Stabilizing tube through the square tube in the bottom of the lift. Secure it with screws supplied (parts # 64)

The final Set-Up for the GL-1 model is complete

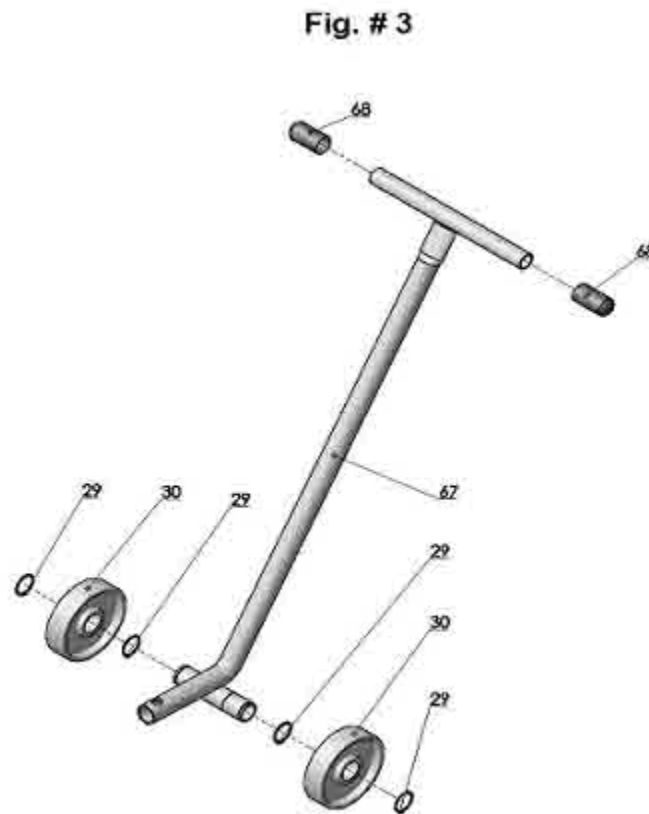

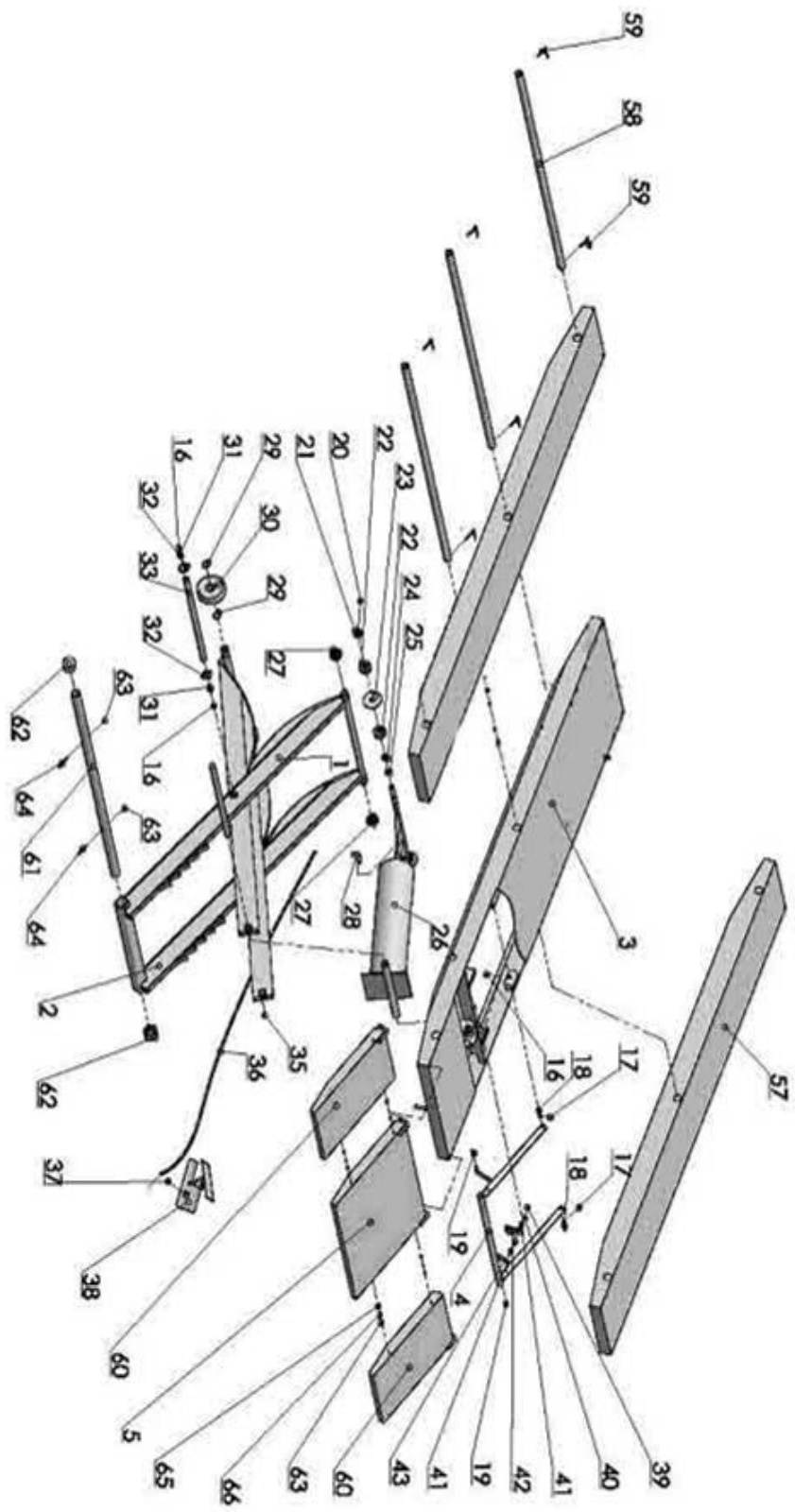

FIG. # 1

PARTS LIST

GL-1

<u>ITEM</u>	<u>PART NUMBER</u>	<u>DESCRIPTION</u>	<u>QTY</u>
1	AL-1000	SCISSOR A	1
2	AL-2000	SCISSOR B	1
3	AL-3000	LIFT TABLE	1
4	AL-4000	SAFETY BAR	1
5	AL-5202	APPROACH RAMP B	1
16	GB1152-89	OIL ZERK M6	4
17	GB91-86	COTTER PIN	2
18	GB882-86	PIN	2
19	AL-4004	PLASTIC GRIP	2
20	GB78-85	SET SCREW	2
21	YG09-9102-4	END RETAINER	2
22	AL-6006	BEARING	4
23	AL-6004	WASHER	2
24	GB95-85	WASHER	2
25	GB894.1-86	SPACER	2
26	YG09-9100	AIR CYLINDER	1
27	AL-6007	BEARING	2
28	YG09-9106	FITTING	1
29	GB894.1-86	SPACER	8
30	AL-5501	WHEEL	4
31	GB894.1-86	SPACER	2
32	30400-1005C	WASHER	2
33	AL-6003	SHAFT	1
34	AL-6002	SHAFT	1
35	GB77-85	SET SCREW	2
36	YG09-9301	AIR HOSE	1
37	YG09-9107	FITTING	1
38	YG09-9300	FOOT-OPERATED VALVE	1

<u>ITEM</u>	<u>PART NUMBER</u>	<u>DESCRIPTION</u>	<u>QTY</u>
39	GB41-86	NUT M5	1
40	GB93-87	LOCK WASHER	1
41	GB95-85	WASHER	2
42	AL-6001	SAFETY BAR HOLDER	1
43	GB5781-86	BOLT M5*16	1
44	GB67-85	BOLT M6*10	1
45	GB96-85	WASHER	1
46	AL-5402	PLASTIC HANDLE	1
47	GB879-86	PIN 6*20	1
48	AL-5420	HANDLE	1
49	GB95-85	WASHER	1
50	AL-5401	SCREW	1
51	AL-5410	BASE, MOVING JAW	1
52	AL-5302C	NUT	1
53	AL-5302B	SLEEVE	1
54	GB879-86	PIN 4*40	1
55	AL-5302-1	WELDMENT, MOVING JAW	1
56	AL-5302D	SUPPORT STUD	1
57	AL-5101	SIDE EXTENSION	2
58	AL-5601	EXTENSION PANEL TUBE	3
59	AL-5605	LOCKING CLIPS	6
60	AL-5201	APPROACH RAMP, SIDE EXT	2
61	AL-5602	STABILIZING TUBE	1
62	AL-5603	END CAP, STABILIZING TUBE	2
63	GB41-86	NUT M6	6
64	GB5781-86	LOCKING BOLTS M6*50	2
65	GB5781-86	BOLT M6*16	4
66	GB93-87	WASHER	4
67	AL-5510	DOLLY	1
68		PLASTIC HANDLE GRIP	2